



کد رنگ سیم ها

Color	Code	Color	Code
Black	B	Light Green	LG
Brown	BR	Orange	O
Dark blue	DL	Pink	P
Dark Green	DG	Red	R
Gray	GR	Sky Blue	SB
Green	G	Violet	V
Light blue	LB	White	W
Blue	L	Yellow	Y

## نماد

Name	Symbol	Name	Symbol
Front harness	F 	Grounding harness	EA
Engjne harness	E 	Interior harness	IN
EM harness	EM	Reversing radar harness	RA
Middle harness	D 	2# Back door harness	R2#
Rear harness	R 	1# Back door harness	R1#
Front left door harness	DR1		
Front right door harness	DR2		
Rear left door harness	DR3		
Rear right door harness	DR4		
Instrument harness	I		

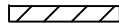
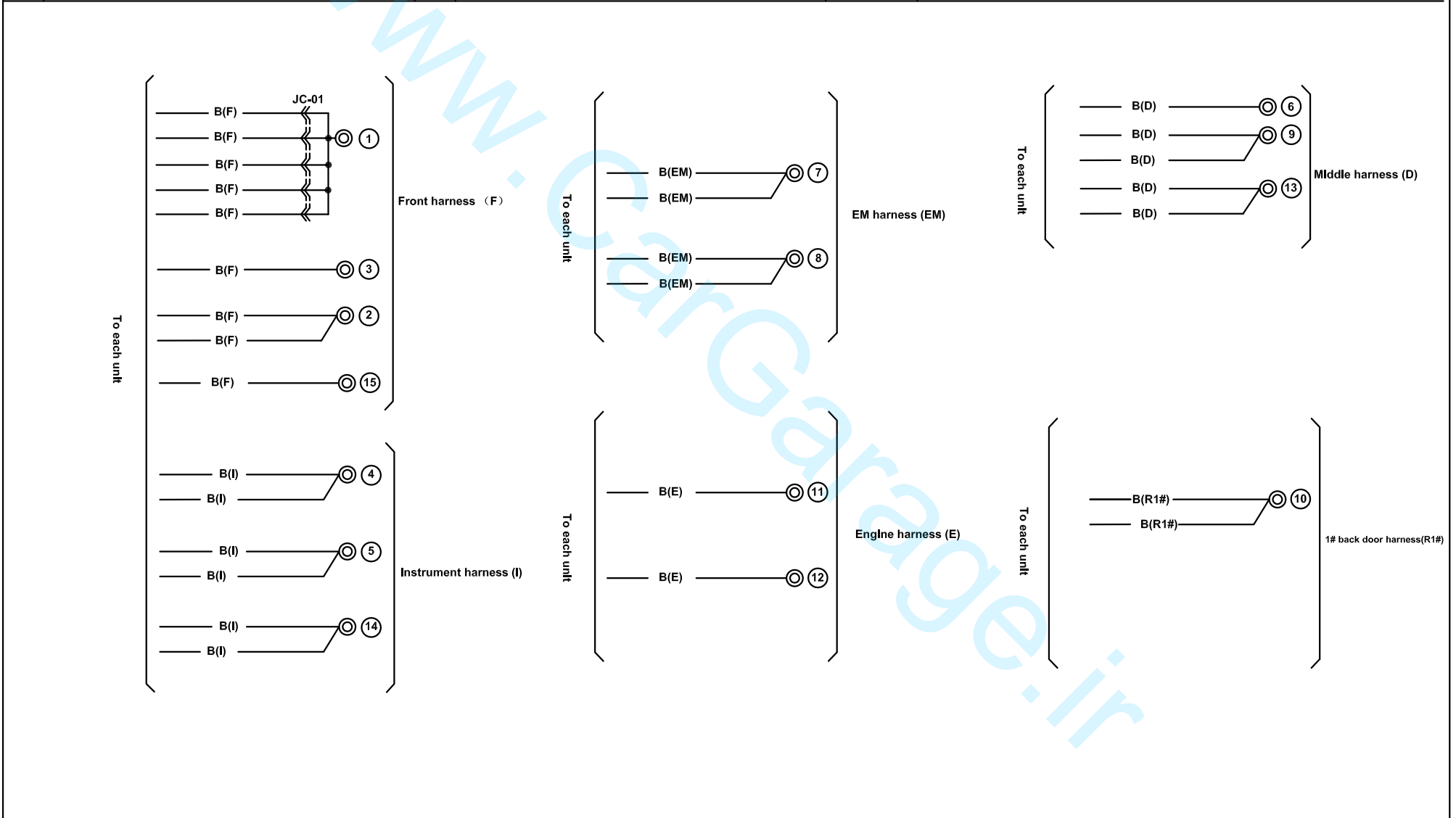
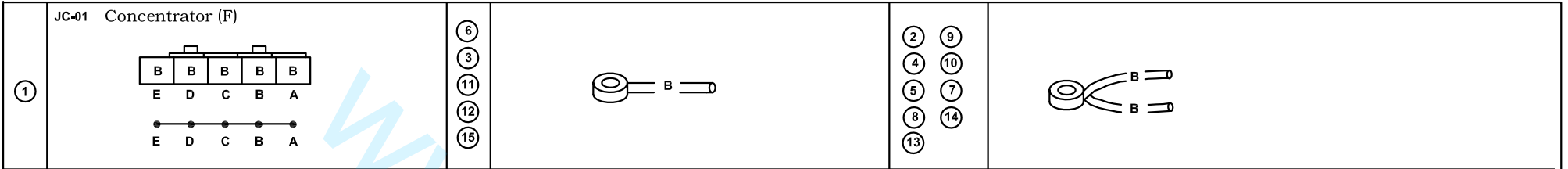

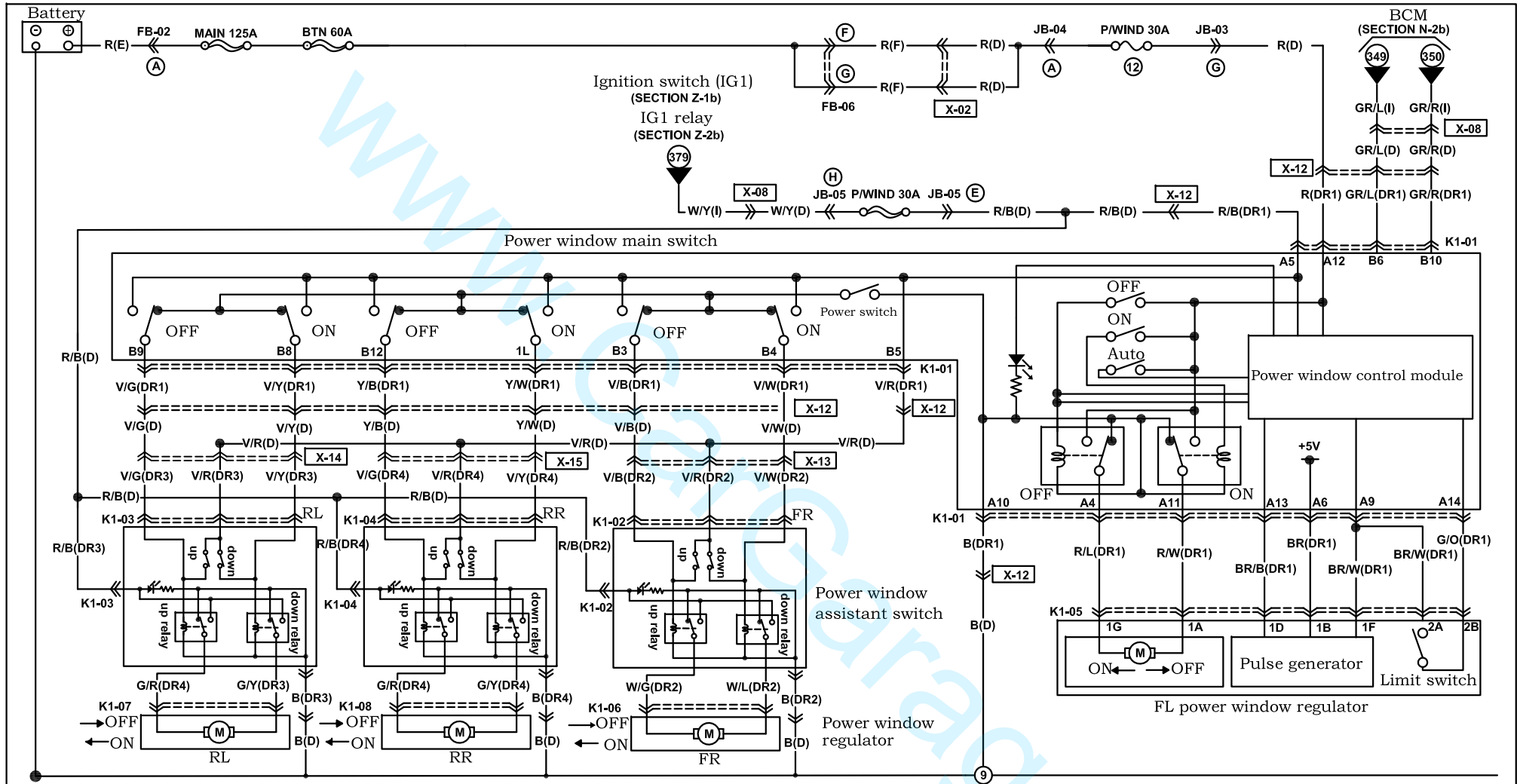

<p><b>K1-01</b> Power window main switch (DR1)</p> <table border="1"> <tr> <td>A1</td><td></td><td></td><td></td><td></td><td></td><td>A7</td> </tr> <tr> <td>*</td><td>*</td><td>*</td><td>R/L</td><td>R/B</td><td>BR</td><td>*</td> </tr> <tr> <td>*</td><td>BR/W</td><td>B</td><td>R/W</td><td>R</td><td>BR/B</td><td>G/O</td> </tr> <tr> <td>A8</td><td></td><td></td><td></td><td></td><td></td><td>A14</td> </tr> </table>	A1						A7	*	*	*	R/L	R/B	BR	*	*	BR/W	B	R/W	R	BR/B	G/O	A8						A14	<table border="1"> <tr> <td>B1</td><td></td><td></td><td></td><td></td><td>B6</td> </tr> <tr> <td>*</td><td>*</td><td>V/B</td><td>V/W</td><td>V/R</td><td>GR/L</td> </tr> <tr> <td>*</td><td>V/Y</td><td>V/G</td><td>GR/R</td><td>Y/W</td><td>Y/B</td> </tr> <tr> <td>B7</td><td></td><td></td><td></td><td></td><td>B12</td> </tr> </table>	B1					B6	*	*	V/B	V/W	V/R	GR/L	*	V/Y	V/G	GR/R	Y/W	Y/B	B7					B12	<p><b>K1-02</b> FR power window assistant switch (DR2)</p> <table border="1"> <tr> <td>C1</td><td></td><td></td><td></td><td></td><td>C6</td> </tr> <tr> <td>V/W</td><td>*</td><td>W/G</td><td>V/R</td><td>B</td><td>*</td> </tr> <tr> <td>V/B</td><td>R/B</td><td>W/L</td><td>*</td><td>*</td><td>*</td> </tr> <tr> <td>C7</td><td></td><td></td><td></td><td></td><td>C12</td> </tr> </table>	C1					C6	V/W	*	W/G	V/R	B	*	V/B	R/B	W/L	*	*	*	C7					C12	<p><b>K1-03</b> RL power window assistant switch (DR3)</p> <table border="1"> <tr> <td>C1</td><td></td><td></td><td></td><td></td><td>C6</td> </tr> <tr> <td>V/Y</td><td>*</td><td>G/R</td><td>V/R</td><td>B</td><td>*</td> </tr> <tr> <td>V/G</td><td>R/B</td><td>G/Y</td><td>*</td><td>*</td><td>*</td> </tr> <tr> <td>C7</td><td></td><td></td><td></td><td></td><td>C12</td> </tr> </table>	C1					C6	V/Y	*	G/R	V/R	B	*	V/G	R/B	G/Y	*	*	*	C7					C12
A1						A7																																																																																																	
*	*	*	R/L	R/B	BR	*																																																																																																	
*	BR/W	B	R/W	R	BR/B	G/O																																																																																																	
A8						A14																																																																																																	
B1					B6																																																																																																		
*	*	V/B	V/W	V/R	GR/L																																																																																																		
*	V/Y	V/G	GR/R	Y/W	Y/B																																																																																																		
B7					B12																																																																																																		
C1					C6																																																																																																		
V/W	*	W/G	V/R	B	*																																																																																																		
V/B	R/B	W/L	*	*	*																																																																																																		
C7					C12																																																																																																		
C1					C6																																																																																																		
V/Y	*	G/R	V/R	B	*																																																																																																		
V/G	R/B	G/Y	*	*	*																																																																																																		
C7					C12																																																																																																		
<p><b>K1-06</b> FR power window regulator (DR2)</p> <table border="1"> <tr> <td>W/G</td> </tr> <tr> <td>W/L</td> </tr> </table>	W/G	W/L	<p><b>K1-07</b> RL power window regulator (DR3)</p> <table border="1"> <tr> <td>G/Y</td> </tr> <tr> <td>G/R</td> </tr> </table>	G/Y	G/R	<p><b>K1-08</b> RR power window regulator (DR4)</p> <table border="1"> <tr> <td>G/Y</td> </tr> <tr> <td>G/R</td> </tr> </table>	G/Y	G/R	<p><b>K1-04</b> RR power window assistant switch (DR4)</p> <table border="1"> <tr> <td>C1</td><td></td><td></td><td></td><td></td><td>C6</td> </tr> <tr> <td>V/Y</td><td>*</td><td>G/R</td><td>V/R</td><td>B</td><td>*</td> </tr> <tr> <td>V/G</td><td>R/B</td><td>G/Y</td><td>*</td><td>*</td><td>*</td> </tr> <tr> <td>C7</td><td></td><td></td><td></td><td></td><td>C12</td> </tr> </table>	C1					C6	V/Y	*	G/R	V/R	B	*	V/G	R/B	G/Y	*	*	*	C7					C12	<p><b>K1-05</b> FL power window regulator (DR1)</p> <table border="1"> <tr> <td>1A</td><td>R/W</td><td></td><td></td><td>R/L</td> </tr> <tr> <td>1B</td><td>BR</td><td>BR/B</td><td>BR/W</td><td>*</td> </tr> <tr> <td></td><td></td><td></td><td></td><td>1F</td> </tr> </table>	1A	R/W			R/L	1B	BR	BR/B	BR/W	*					1F																																																						
W/G																																																																																																							
W/L																																																																																																							
G/Y																																																																																																							
G/R																																																																																																							
G/Y																																																																																																							
G/R																																																																																																							
C1					C6																																																																																																		
V/Y	*	G/R	V/R	B	*																																																																																																		
V/G	R/B	G/Y	*	*	*																																																																																																		
C7					C12																																																																																																		
1A	R/W			R/L																																																																																																			
1B	BR	BR/B	BR/W	*																																																																																																			
				1F																																																																																																			

